

# Barracuda

JAMES & TAYLOR  
SOLUTIONS OUTSIDE THE BOX

## INSTALLATION GUIDE



## Barracuda Brick Slip Support System - Installation Guide

### Identification of [delivered] Materials

Please refer to James & Taylor despatch notes for the quantities and types of materials that have been delivered. The different types of Barracuda materials supplied can be identified by reference to labelling adhered to pallet wrapping or boxes.

The Barracuda Brick Slip Support System consists of the following principal components

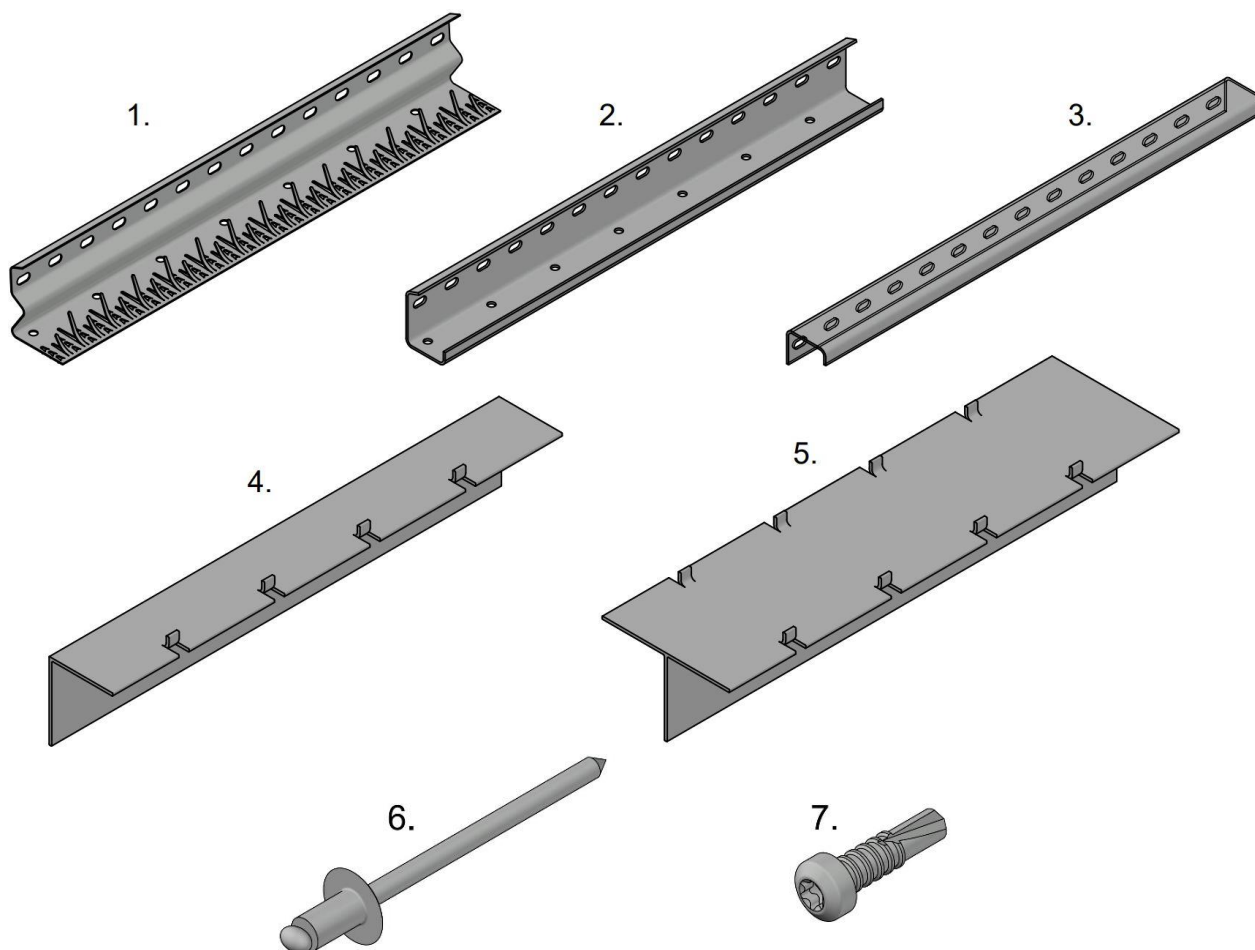

### Principal Components

- |                              |   |
|------------------------------|---|
| 1. Barracuda 'Standard' Rail | - Component Ref: BAR-R1-2400            |
| 2. Barracuda 'Bottom' Rail   | - Component Ref: BAR-R2-2400            |
| 3. Barracuda 'Top' Rail      | - Component Ref: BAR-R3-2400            |
| 4. Barracuda 'L' Rail        | - Component Ref: BAR-VL- [length in mm] |
| 5. Barracuda 'T' Rail        | - Component Ref: BAR-VT- [length in mm] |

### Fasteners

- |   |
|---|
| 6. Rivet to fix 'Standard' and 'Bottom' Barracuda Rails -<br>Component Ref: 4.8 x 8mm Long <u>All</u> Stainless Steel [both body and mandrel]<br>Rivet Product Ref: 01260004808 [or alternative rivet providing equivalent or better performance].    |
| 7. Self-Drilling/Self Tapping Screw to fix 'Top' Barracuda Rails -<br>Component Ref: Ejot JT4-ZT-4-4.8 x 19mm Long - without sealing washer [or<br>alternative screw providing equivalent or better performance with equivalent screw head diameter]. |

## Barracuda Brick Slip Support System - Installation Guide

The following 'special' tools are required for installation

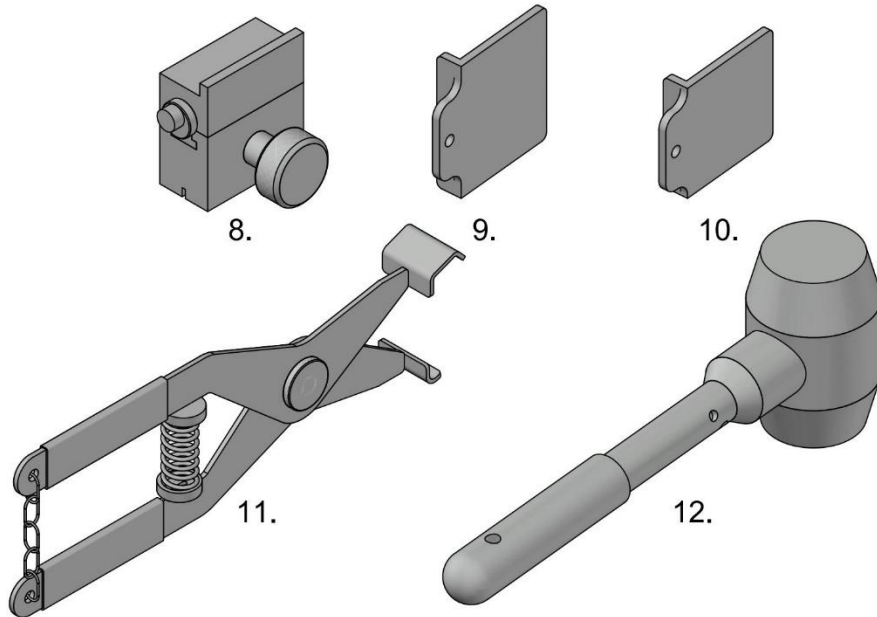

### Special Tools

- 8. Bottom Rail 'Setting Blocks'
- 9. Vertical Rail Marking Square - Top
- 10. Vertical Rail Marking Square - Bottom
- 11. Bottom Brick Slip Installation Tool
- 12. Blond Dead Blow Soft Mallet

The following 'standard' tools are usually required for installation *[This illustration and the following list are not intended to be absolutely exhaustive].*

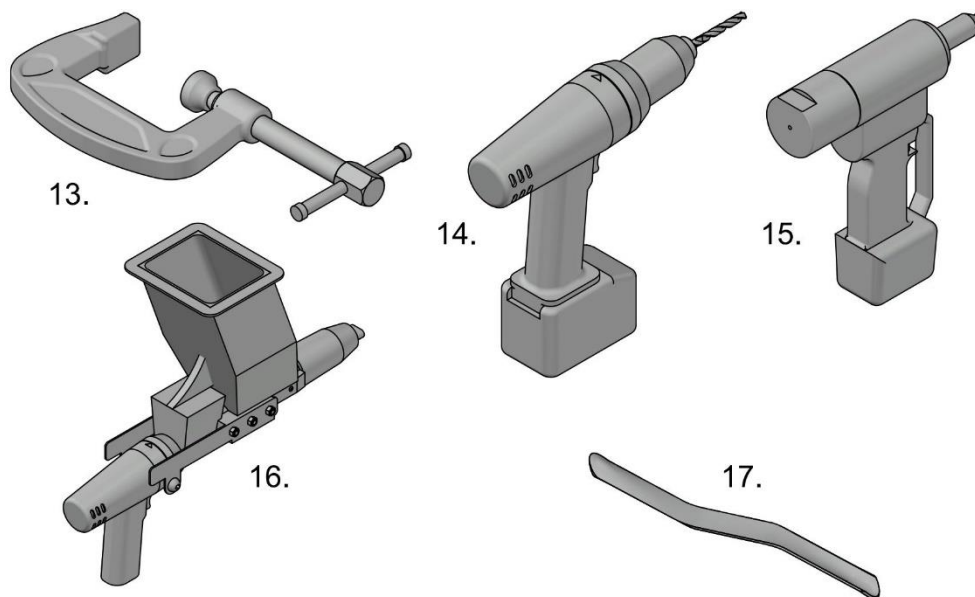

### Standard Tools

- 13. 'G' Cramp[s]
- 14. Cordless Drill [with drill bits]
- 15. Rivet Gun
- 16. Mortar Applicator
- 17. Joint Finishing Tool

## **Barracuda Brick Slip Support System - Installation Guide**

### **Delivery, Offloading and Storage of Barracuda Materials**

Barracuda rails are supplied heat shrink wrapped and palletised. These may be 'fork-lifted' or craned from the delivery vehicle.

1000 No. BAR-R1-2400 'standard' rails [180M<sup>2</sup>] are normally supplied on a single pallet with an 'all-inclusive' weight of approximately 1350kg per pallet.

10 No. pallets [10000 No. rails/1800M<sup>2</sup>] can normally be supplied on a typical 40T articulated delivery vehicle. This constitutes a typical 'full load'.

Dependent upon the project floor to floor height/brick slip cladding configuration, usually, approximately one bottom [R2] rail and one top [R3] rail will be required for every 40 No. R1 rails supplied.

Quantities of bottom [R2] rail and top [R3] rail corresponding to a 'full load' of standard [R1] rails might typically be;

250 No. BAR-R2-2400 'bottom' rails supplied on a single pallet will have an 'all-inclusive' weight of approximately 590kg per pallet.

250 No. BAR-R3-2400 'top' rails supplied on a single pallet will have an 'all-inclusive' weight of approximately 455kg per pallet.

Quantities of Barracuda 'L' and 'T' aluminium substructure rails [based upon idealised 600mm fixing centres] corresponding to a 'full load' of standard [R1] rails might typically be;

756 No. BAR-VL-2990 'L' rails supplied on a single pallet will have an 'all-inclusive' weight of approximately 1495kg per pallet.

264 No. BAR-VT-2990 'T' rails supplied across two pallets will have an 'all-inclusive' weight of approximately 415kg per pallet.

The heat shrink wrapped palletised Barracuda rails can be stored either outside or under-cover. In both cases they must be 'set down' on a reasonably flat area of 'hard standing'.

Do not stack pallets of Barracuda rails on top of one another and do not stack or store other materials on top of the Barracuda rails.

Other Barracuda materials; fasteners and special tools will be supplied in cardboard boxes. Boxed Barracuda materials should be stored in a dry, covered environment to ensure that the cardboard boxes don't deteriorate.

## Barracuda Brick Slip Support System - Installation Guide

### Unpackaging the Barracuda Materials

Remove the screws securing the 'crossmembers' to the Barracuda pallet and remove the 'crossmembers'. Leave the vertical upright retaining timbers in place so that the Barracuda rails remain neatly stacked on the pallet and don't 'spill' off the sides of the pallet.

Cut the top of the heat shrink wrapping down its centre and ends so that the top of the heat shrink wrapping can be 'folded back'. Progressively cut down one end of the heat shrink wrapping so that the Barracuda rails can be readily removed from the pallet whilst retaining stability of the palletised materials and maximising their protection.

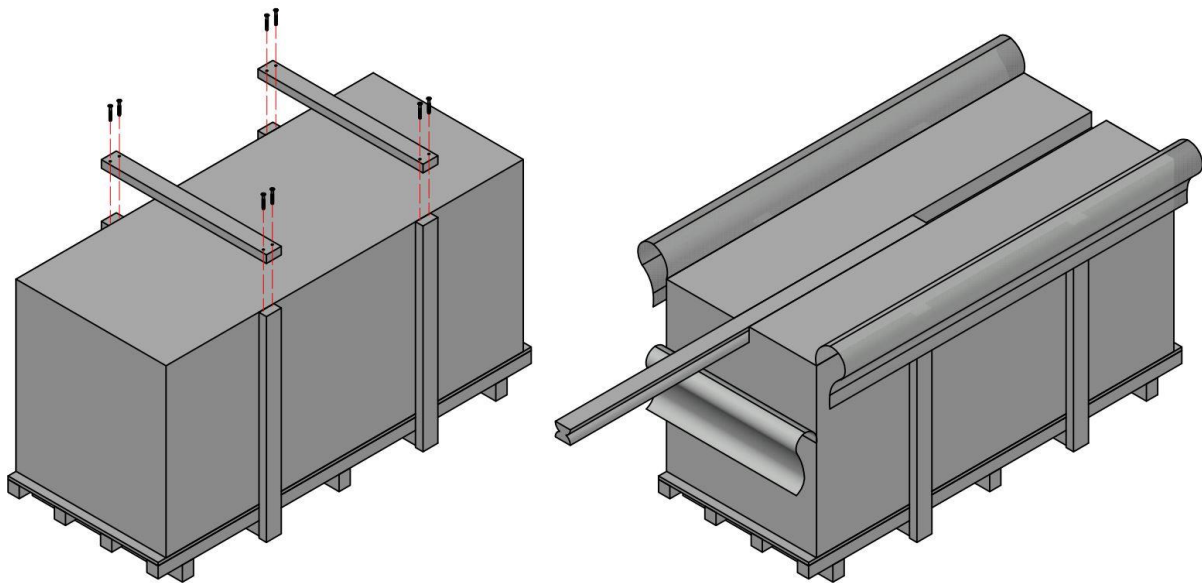

### Brick Slips Compatible with the Barracuda Brick Slip System

Almost all brick types compliant with BS EN 771 are compatible with the Barracuda brick slip support system. Some brick types are however inherently very fragile when cut into typical brick slip thicknesses. The Barracuda brick slip support system is more tolerant of very fragile bricks because the Barracuda brick slip thickness is 40mm. It is however important that the brick type intended for use with the Barracuda brick slip support system is confirmed by James & Taylor as being suitable for use with the Barracuda system.

Brick slips must be cut in accordance with James & Taylor Barracuda brick slip cutting drawings; CU-B-101 to CU-B-104RH-R. There are currently 13 No. drawings in this drawing series. Please contact James & Taylor should you wish to be provided with these drawings.

In order to assist with the brick slip cutting process, James & Taylor can provide 'cutting jigs' and saw 'setting blocks' that enable the correct and accurate set-up of suitable [typical] brick cutting saw machinery. Please contact James & Taylor should you wish to discuss the provision of these cutting jigs and saw setting blocks.

## Barracuda Brick Slip Support System - Installation Guide

### Preparing for Installation

Prior to installation it is important to thoroughly familiarise yourself with all of the James & Taylor Barracuda brick slip support system 'Typical Detail' drawings that might be applicable to your project.

There are currently 21 No. 'Typical Detail' drawings; TD-B-101 to TD-B-121

Please contact James & Taylor should you wish to be provided with these drawings.

Other, 'project specific' drawings might have been produced by James & Taylor for your project and other 'builders work drawings' might have been produced by, commissioned by, or issued to your company that communicate the construction requirements. Please familiarise yourself with all drawings that might be applicable to the installation of the Barracuda brick slip support system and its interface with adjacent materials.

It is important that the Barracuda brick slip support system is installed in the correct position. Builders work drawings should provide 'reduced levels' that indicate the level of the tops and bottoms of areas of brick slip cladding and 'offset dimensions', from the building's 'grid lines', that indicate where the front face of the brick slip cladding should be positioned. It is important to understand that the building's structure [steel or concrete frame] and infill backing walls [typically lightweight metal framing or blockwork] might not have been constructed accurately. Usually, the surfaces and structures to which any brick slip cladding system will be fixed should be 'surveyed' to ascertain the extent of any lack of accuracy. The results of this survey can then be taken into account when positioning the brick slip cladding system.

### Installation of Barracuda 'L' and 'T' Aluminium Substructure Rails

Barracuda 'L' and 'T' aluminium substructure rails feature integral brick course 'gauge tabs'. These gauge tabs enable more rapid and accurate installation of the Barracuda R1 rails. The gauge tabs are positioned at 75mm centres [standard brick course height] along the length of the 'L' and 'T' aluminium substructure rails.

Barracuda 'L' and 'T' aluminium substructure rails are normally supplied by James & Taylor already cut to the required lengths. The lengths required will need to be specifically ordered from James & Taylor.

If Barracuda 'L' and 'T' aluminium substructure rails need to be cut to length on site they must be cut so that the bottom of the rail is cut 68mm below the top of the lowest gauge tab and the top of the rail is cut 72mm above the top of the uppermost gauge tab. James & Taylor can provide special vertical rail 'Marking Square' tools that enable the straightforward and accurate marking of these dimensions onto the 'L' and 'T' rails so that they can then be accurately cut. See Fig.1

## Barracuda Brick Slip Support System - Installation Guide

Please also refer to Barracuda Typical Details: TD-B-104 and TD-B-105

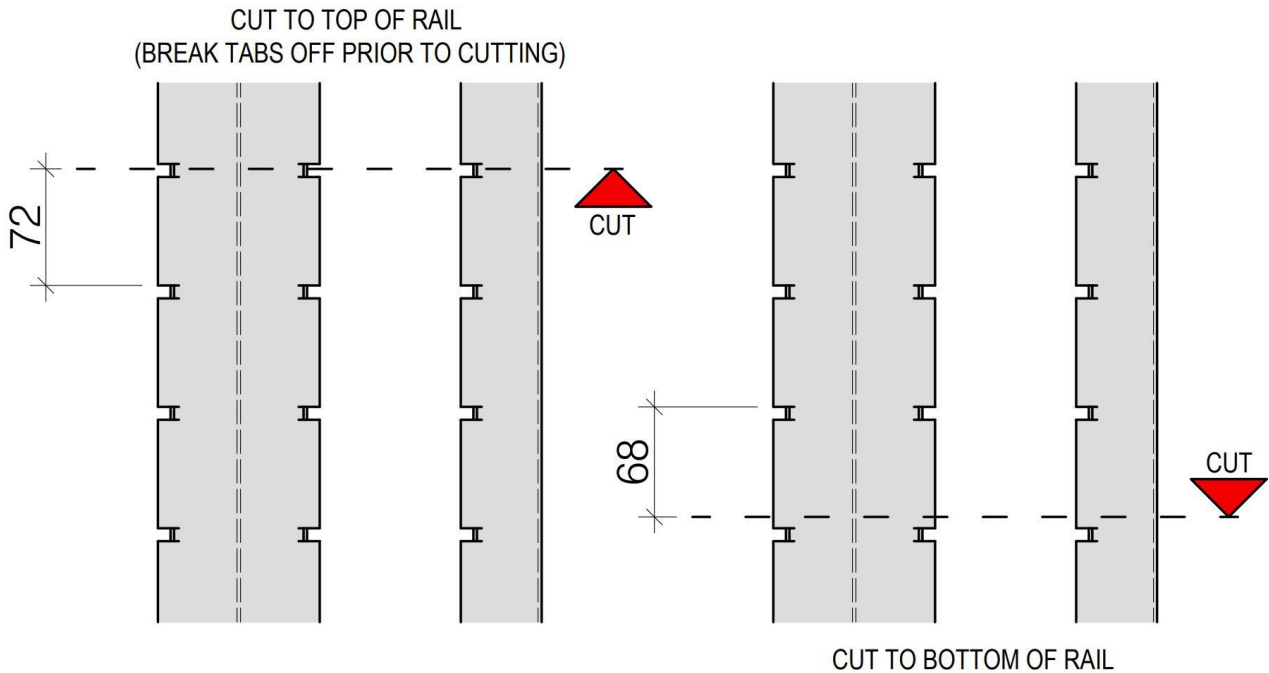

**Fig.1**

Barracuda ‘L’ and ‘T’ rails are designed so that they will be compatible with [fit into] most proprietary ‘helping hand’ brackets. The types and positions of helping hand brackets and their fastening method should be indicated on your ‘builders work drawings’. The adequacy of the helping hand bracket configuration [bracket types, positions/spacings and their fastening method] must be proven by recognised calculation method and/or suitable test.

Push the Barracuda ‘L’ and ‘T’ rails into the helping hand brackets just enough so that they are initially ‘held’ by the helping hand brackets. Before pushing them in too far, check that the ‘L’ and ‘T’ rails are close to the required level and adjust up or down if necessary. Push the Barracuda ‘L’ and ‘T’ rails further into the helping hand brackets until their front face/surface is positioned 50mm behind the design location for the front face of the brick slip cladding. See Fig.2

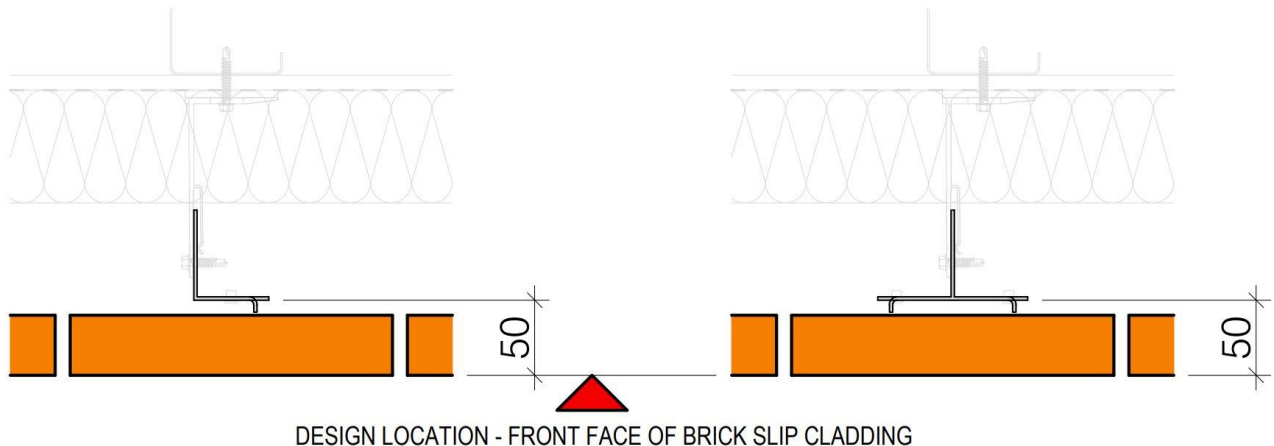

**Fig.2**

## Barracuda Brick Slip Support System - Installation Guide

It is important to make sure that the Barracuda 'L' and 'T' rails are accurately adjusted, to their correct, finalised, level, before securing them to the helping hand brackets. The Barracuda 'L' and 'T' rails should be 'levelled' across the tops of corresponding brick course 'gauge tabs'. See Fig.3

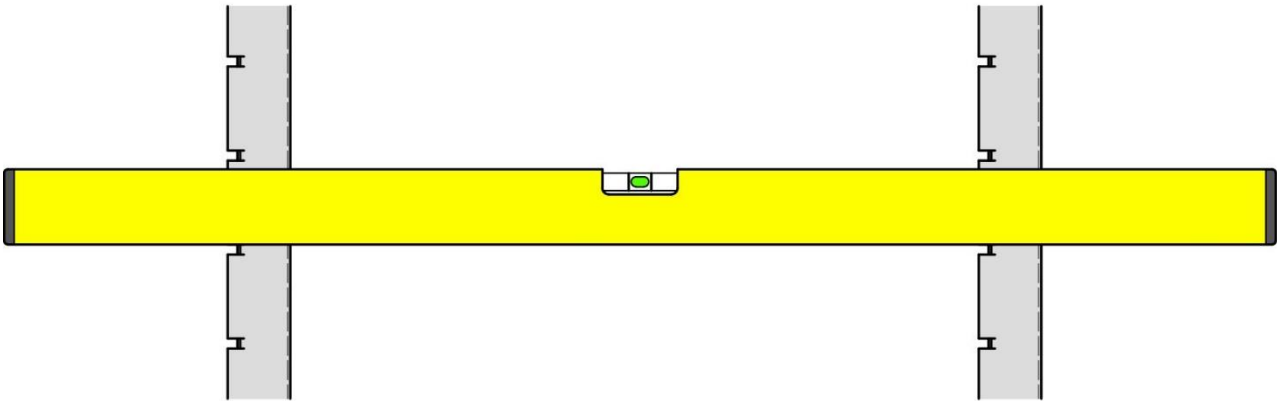

Fig.3

When satisfied that the Barracuda 'L' and 'T' rails are accurately adjusted to their correct and finalised level and that they are accurately adjusted so that their face is 50mm behind the design location of the front face of the brick slip cladding [usually the requirement will be for the 'L' and 'T' rails to be 'vertical'] the 'L' and 'T' rails should be temporarily clamped to the helping hand brackets to ensure that they do not move during drilling/installation of the helping hand to 'L' and 'T' rail fasteners. The Barracuda 'L' and 'T' rails can be secured to the helping hand brackets with either, suitable stainless steel self-drilling/self-tapping screws or suitable stainless steel rivets.

Barracuda 'L' and 'T' rails are situated at maximum 600mm centres behind the 'standard' Barracuda R1 rails [and R2 and R3 rails]. Barracuda 'T' rails occur at the junction between the ends of adjacent Barracuda R1 rails [and R2 and R3 rails]. See Fig.4

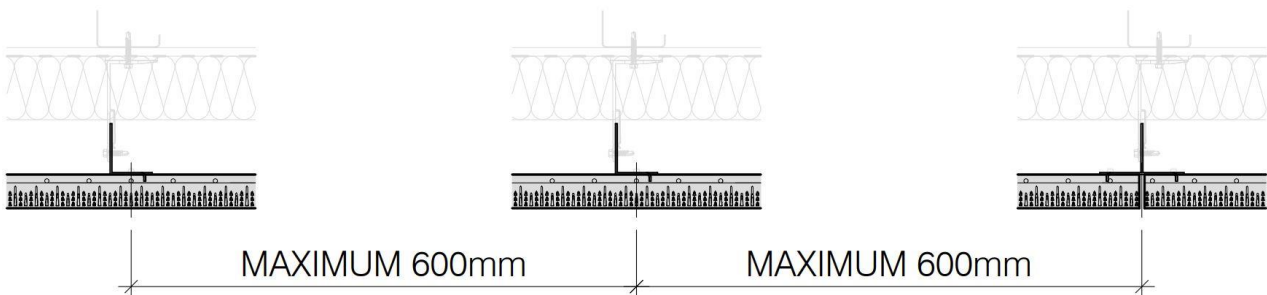

Fig.4

## Barracuda Brick Slip Support System - Installation Guide

### Installation of 'Standard' Barracuda R1 Rails

The 'Standard' Barracuda R1 rails are simply placed onto the brick course gauge tabs and secured to the Barracuda 'L' and 'T' rails with 4.8 x 8mm long stainless steel rivets. Rivet Product Ref: 01260004808 *[or alternative rivet providing equivalent or better performance]*.

When placing the 'Standard' Barracuda R1 rails, ensure that their 'back leg' is flat against the surface of the Barracuda 'L' or 'T' rail and a slight/moderate downward pressure is applied to make sure that the 'heel' of the 'Standard' Barracuda R1 rail 'sits down on' its gauge tabs. See Fig.5

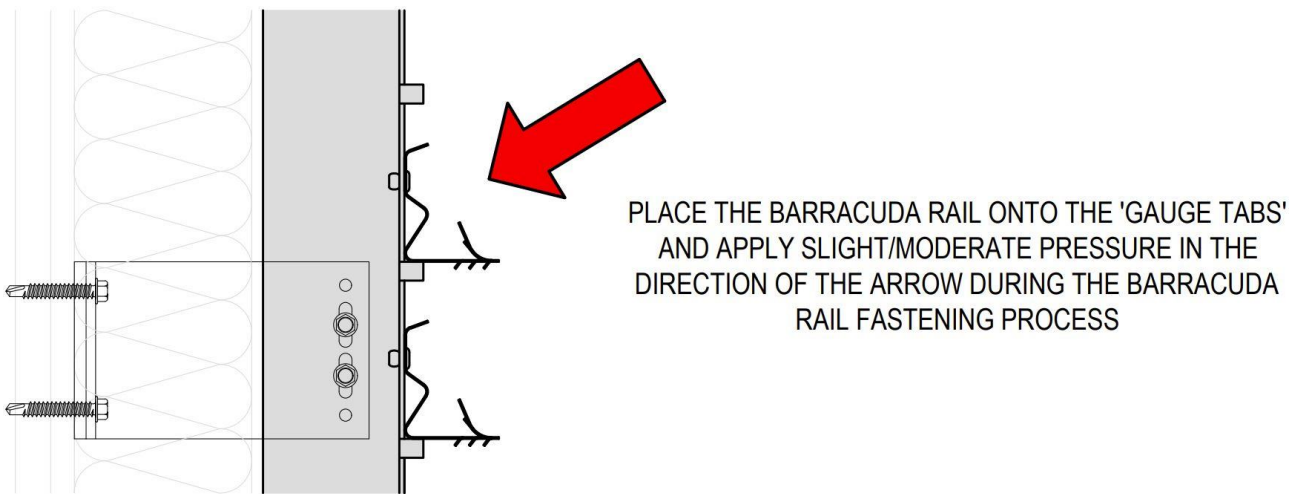

Fig.5

Standard Barracuda R1 rails should be installed with a 6mm gap between the adjacent ends of the rails. This 6mm gap should be very approximately centred on the face of the Barracuda 'T' rail. The Barracuda R1 to 'L' or 'T' fasteners can be situated very close to the lateral leg of the 'L' or the 'T' but should not 'break into' (collide) with the lateral leg. The Barracuda R1 to 'L' or 'T' fasteners should be positioned no closer to the edge of the L' or the 'T' than 10mm. This minimum 'edge distance' dimension should be measured from the centre of the fastener to the edge of the 'L' or 'T' rail. See Fig.6

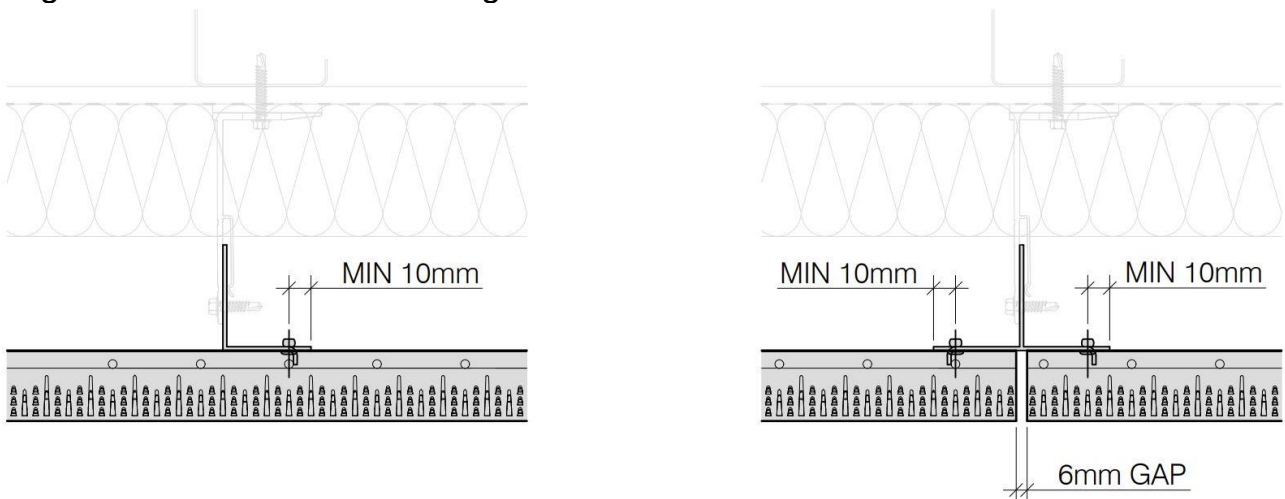

Fig.6

## Barracuda Brick Slip Support System - Installation Guide

### Installation of 'Bottom' Barracuda R2 Rails

'Bottom' Barracuda R2 rails must be installed at a level that is relative to the R1 rail situated immediately above. In order to achieve this, the Barracuda 'Setting Blocks' are used. The Barracuda setting blocks ensure that there is the correct gap between the top of the upturned lip on the bottom R2 rail and the underside of the R1 rail. Distribute 4 No. setting blocks approximately equidistant along the length of a 2400mm module length R2 rail [fewer setting blocks, 3 No. but no fewer than 2 No. can be used when shorter R2 rails are being installed]. Offer up the R2 rail so that the tops of the setting blocks bear against the underside of the R1 rail. Hold the R2 rail firmly so that its vertical leg is flat against the surface of the Barracuda 'L' or 'T' rail and apply some moderate but not excessive upward pressure so that the setting blocks are securely captured between the R1 and R2 rails. With the R2 rail held in this position, the drilling locations can be marked or drilled in-situ through the fastening slots in the R2 rail.

The setting blocks are in two parts to facilitate their removal once the R2 rail has been fixed. In order to remove the setting blocks, rotate the eccentric lock and slide the two halves of the setting block apart. The setting block can now be removed. See Fig.7

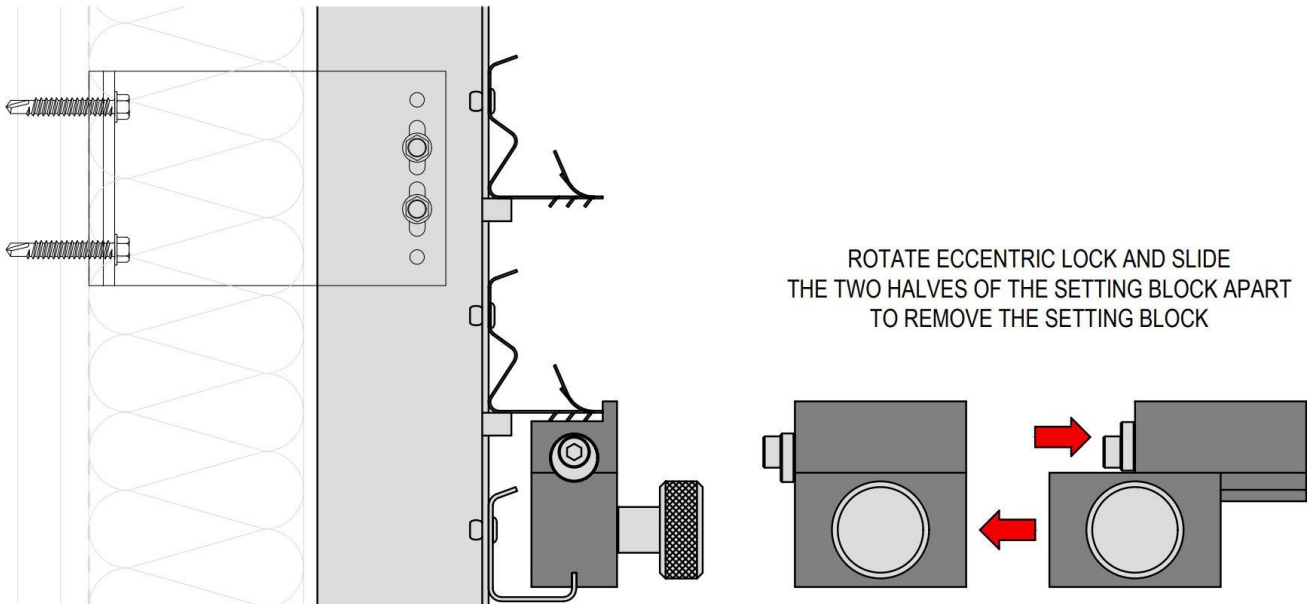

Fig.7

The 'Bottom' Barracuda R2 rails are secured to the Barracuda 'L' and 'T' rails with 4.8 x 8mm long stainless steel rivets. Rivet Product Ref: 01260004808 [or alternative rivet providing equivalent or better performance].

## Barracuda Brick Slip Support System - Installation Guide

Just like the 'Standard' Barracuda R1 rails, The 'Bottom' Barracuda R2 rails should be installed with a 6mm gap between the adjacent ends of the rails. This 6mm gap should be very approximately centred on the face of the Barracuda 'T' rail. The Barracuda R2 to 'L' or 'T' fasteners can be situated very close to the lateral leg of the 'L' or the 'T' but should not 'break into' (collide) with the lateral leg. The Barracuda R2 to 'L' or 'T' fasteners should be positioned no closer to the edge of the L' or the 'T' than 10mm. This minimum 'edge distance' dimension should be measured from the centre of the fastener to the edge of the 'L' or 'T' rail.

### Installation of 'Top' Barracuda R3 Rails

'Top' Barracuda R3 rails must be installed so that the top/uppermost horizontal surface of the R3 rail is 72mm above the top of the uppermost gauge tab. The top Barracuda R3 rails are secured to the Barracuda 'L' and 'T' rails with Self Drilling/Self Tapping Screws. Component Ref: Ejot JT4-ZT-4-4.8 x 19mm Long - without sealing washer *[or alternative screw providing equivalent or better performance with equivalent screw head diameter]*. See Fig.8

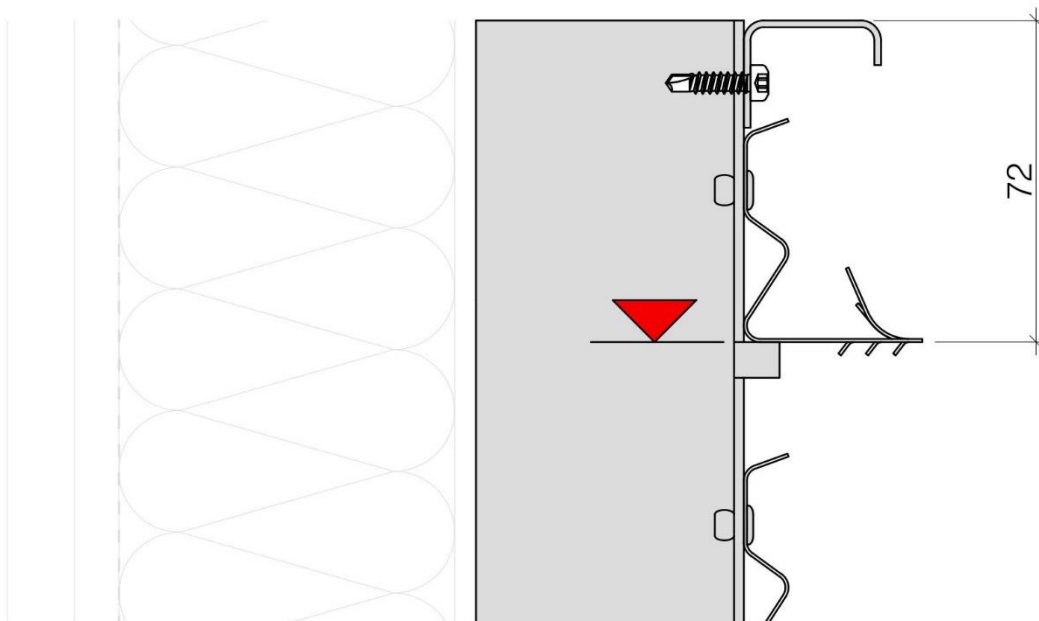

Fig.8

Just like the 'Standard' Barracuda R1 and R2 rails, The 'Top' Barracuda R3 rails should be installed with a 6mm gap between the adjacent ends of the rails. This 6mm gap should be very approximately centred on the face of the Barracuda 'T' rail. The Barracuda R3 to 'L' or 'T' fasteners can be situated very close to the lateral leg of the 'L' or the 'T' but should not 'break into' (collide) with the lateral leg. The Barracuda R3 to 'L' or 'T' fasteners should be positioned no closer to the edge of the L' or the 'T' than 10mm. This minimum 'edge distance' dimension should be measured from the centre of the fastener to the edge of the 'L' or 'T' rail.

## Barracuda Brick Slip Support System - Installation Guide

### Installation of Brick Slips

40mm thick brick slips 'push fit' between the 'Standard' Barracuda R1 rails. Installation can be assisted by the use of a lightweight non-marking elastomeric [rubber] dead blow mallet [James & Taylor can supply the correct/appropriate mallet if required]. Keep the front face of the brick slip close to vertical whilst pushing/tapping the brick slip into position between the Barracuda R1 rails. Push/tap the brick slip all the way into the R1 rails until the rear surface of the brick slip contacts the projecting integral stops. See Fig.9

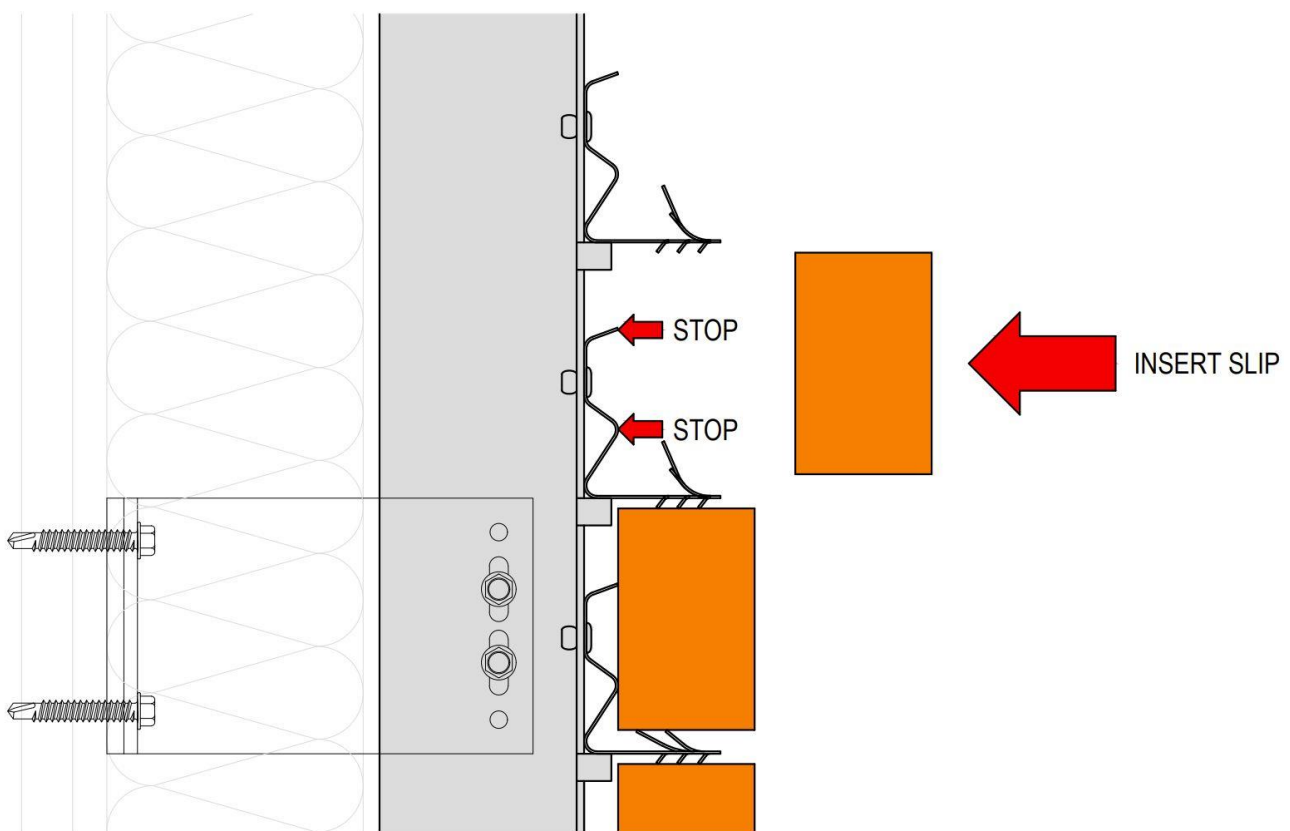

Fig.9

Brick slips can be installed into the Barracuda system in an entirely multi-directional fashion. Brick slips can be installed top down, bottom up, left to right or right to left and pockets of slips or an individual slip can be omitted and inserted into the system at a later date. The only brick slip installation 'sequence' requirement is that the course of slips immediately above the very bottom course of brick slips should be installed after the very bottom course of brick slips has been installed and, in a similar fashion; the course of brick slips immediately below the very top course of brick slips should be installed after the very top course of brick slips has been installed.

## Barracuda Brick Slip Support System - Installation Guide

### Installation of 'Bottom' Brick Slips

The bottom brick slips 'push fit' between the 'Standard' Barracuda R1 rail and the 'Bottom' Barracuda R2 rail. The bottom brick slips must be cut/rebated with the Barracuda 'Base' brick slip prep shown on James & Taylor drawing: CU-B-101. Please contact James & Taylor should you wish to be provided with this drawing.

In order to enable the bottom brick to be inserted, compress the 'Standard' Barracuda R1 rail using the 'Special' Bottom Brick Slip Installation Tool. Compressing the standard R1 rail creates enough clearance for the bottom brick slip to be inserted and the upturned leg on the R2 rail to engage into the rebate in the underside of the bottom brick slip. Use 2 No. bottom brick slip installation tools approximately 150mm apart to insert a typical 215mm long 'stretcher' bottom brick. See Fig.10

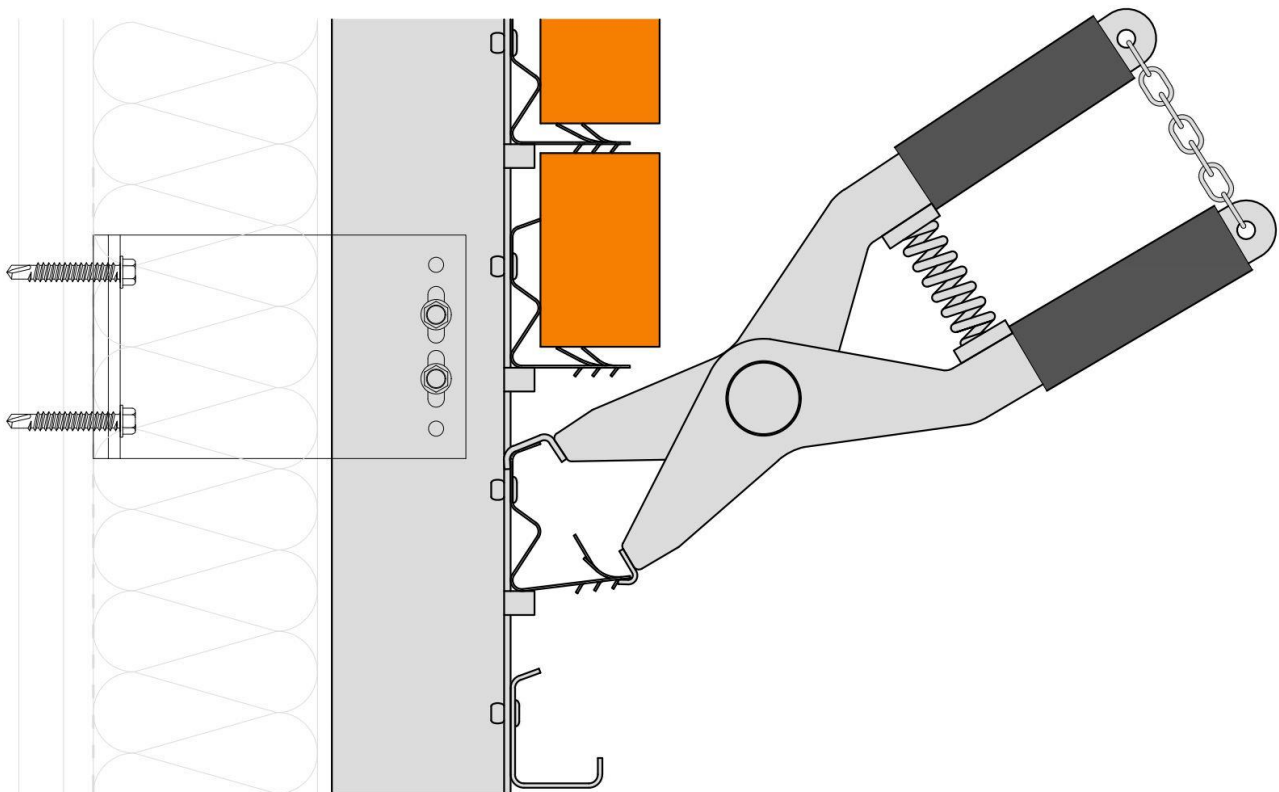
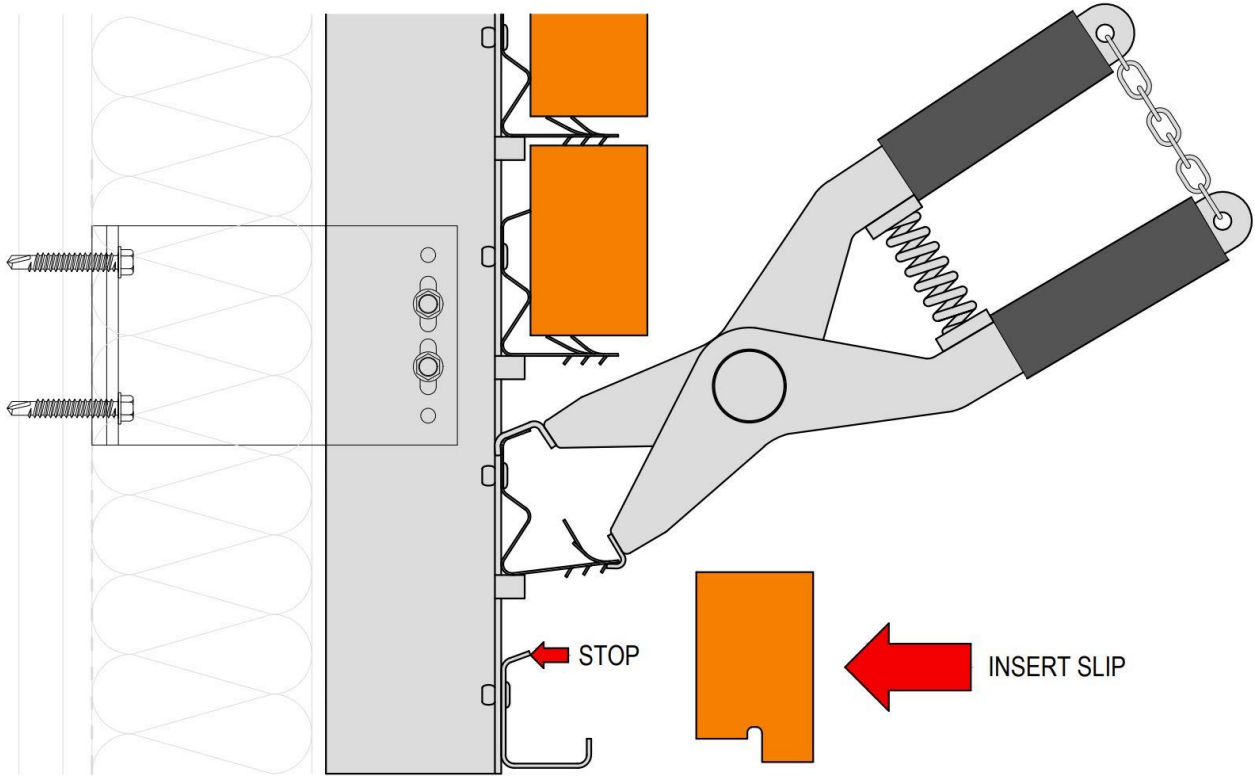

Fig.10

Installation can be assisted by the use of a lightweight non-marking elastomeric [rubber] dead blow mallet [James & Taylor can supply the correct/appropriate mallet if required]. Keep the front face of the bottom brick slip close to vertical whilst pushing/tapping the bottom brick slip into position between the Barracuda R1 and R2 rails. Push/tap the brick slip all the way into the rails until the rear surface of the bottom brick slip contacts the projecting integral stop on the R2 rail and the upturned leg on the R2 rail engages into the rebate in the underside of the bottom brick slip. See Fig.11

## Barracuda Brick Slip Support System - Installation Guide



**Fig.11**

With the bottom brick slips installed, the course of standard brick slips immediately above the bottom brick slips can now be pushed/tapped into position. Installation of these brick slips is just like installation of all other standard brick slips. See Fig.12

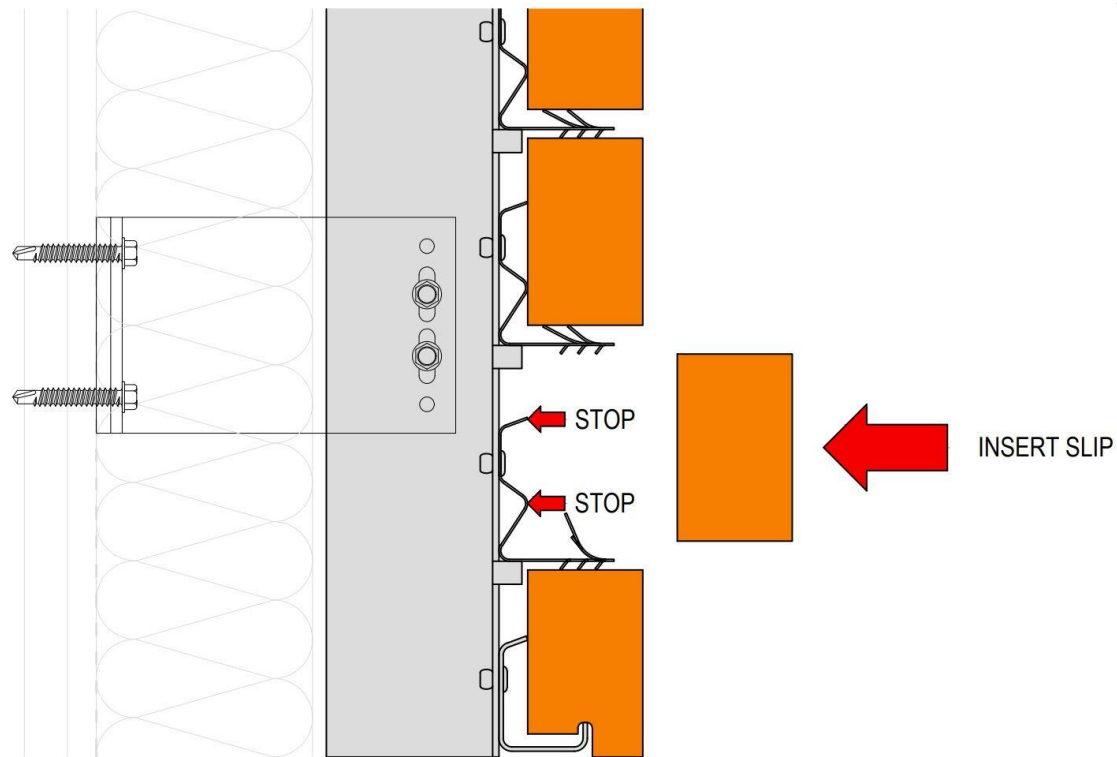

**Fig.12**

## Barracuda Brick Slip Support System - Installation Guide

### Installation of 'Top' Brick Slips

The top brick slips 'push fit' between the 'Standard' Barracuda R1 rail and the 'Top' Barracuda R3 rail. The top brick slips must be cut/rebated with the Barracuda 'Head' brick slip prep shown on James & Taylor drawing: CU-B-101. Please contact James & Taylor should you wish to be provided with this drawing.

Insert the top edge of the top brick slip [first] so that the downturned leg on the R3 rail engages into the rebate in the top brick slip. Then, push the bottom of the top brick slip all the way into the rails until the rear surface of the top brick slip contacts the projecting integral stops on the R1 rail. Usually just a simple push fit by hand is all that is required to install the top bricks but, if necessary, Installation can be assisted by the use of a lightweight non-marking elastomeric [rubber] dead blow mallet [James & Taylor can supply the correct/appropriate mallet if required]. See Fig.13

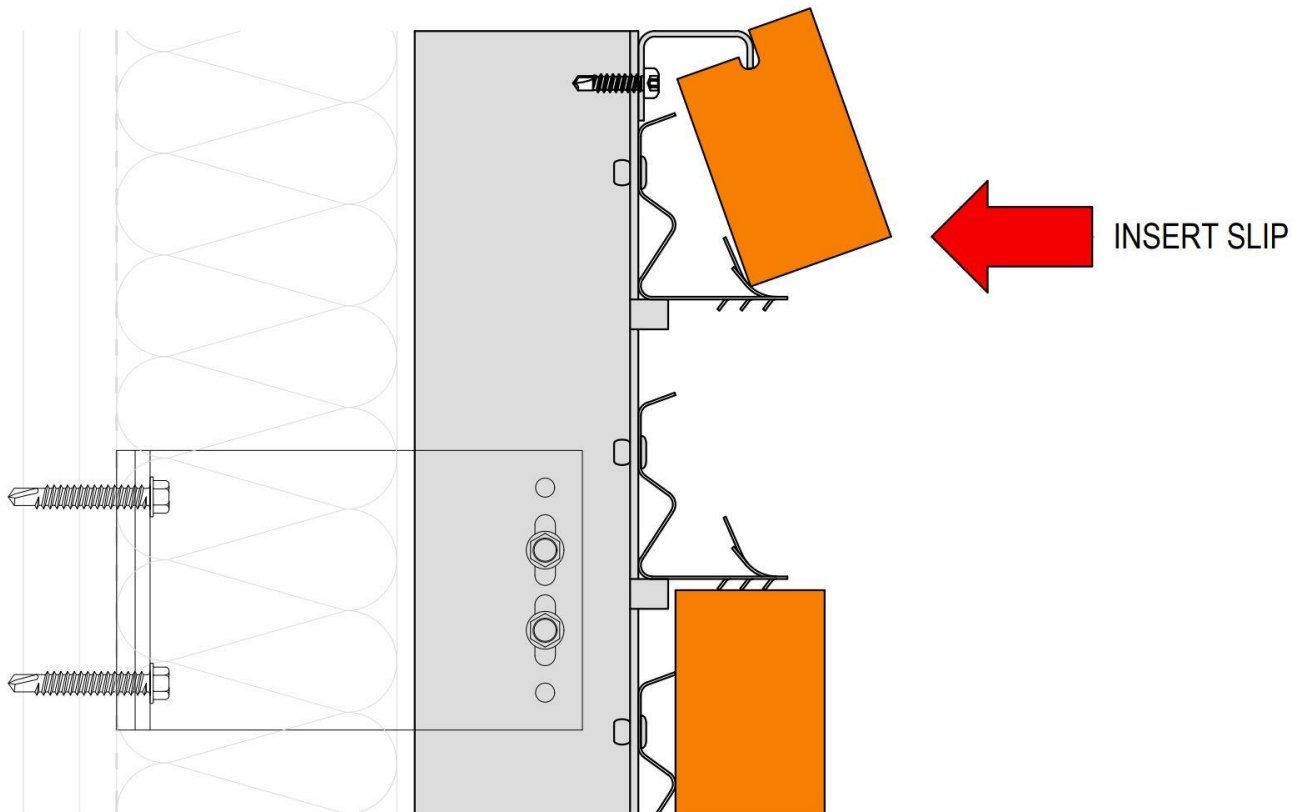

Fig.13

With the top brick slips installed, the course of standard brick slips immediately below the top brick slips can now be pushed/tapped into position. Installation of these brick slips is just like installation of all other standard brick slips. See Fig.14

## Barracuda Brick Slip Support System - Installation Guide

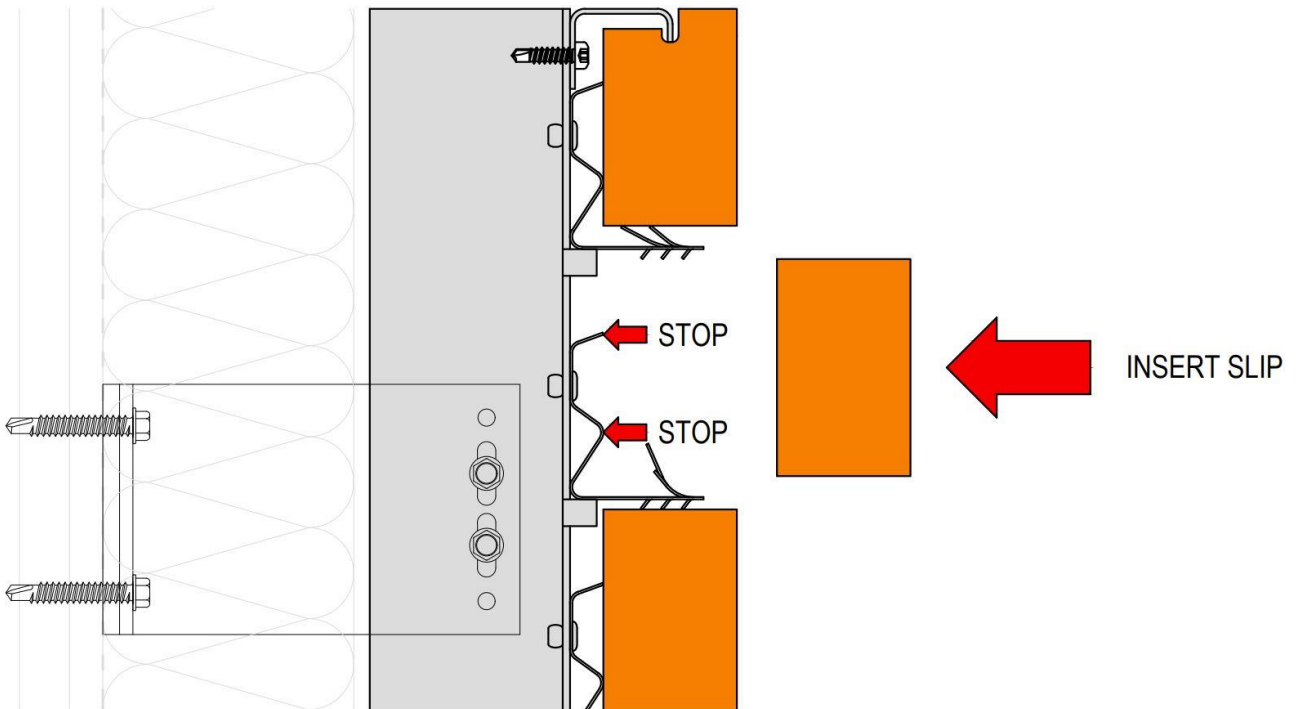

Fig.14

### Adjusting the Position of Installed Brick Slips

The brick slips, once installed can be adjusted either to their left or right if they are found to be not quite in the desired position. Using a large flat bladed screwdriver or small blunt bolster, tap the brick slip to the left or the right [as required]. Should one of the longer 'sprung teeth' impede the travel of the brick slip, apply some light pressure to the tip of the sprung tooth until it is captured beneath the brick slip. See Fig.15

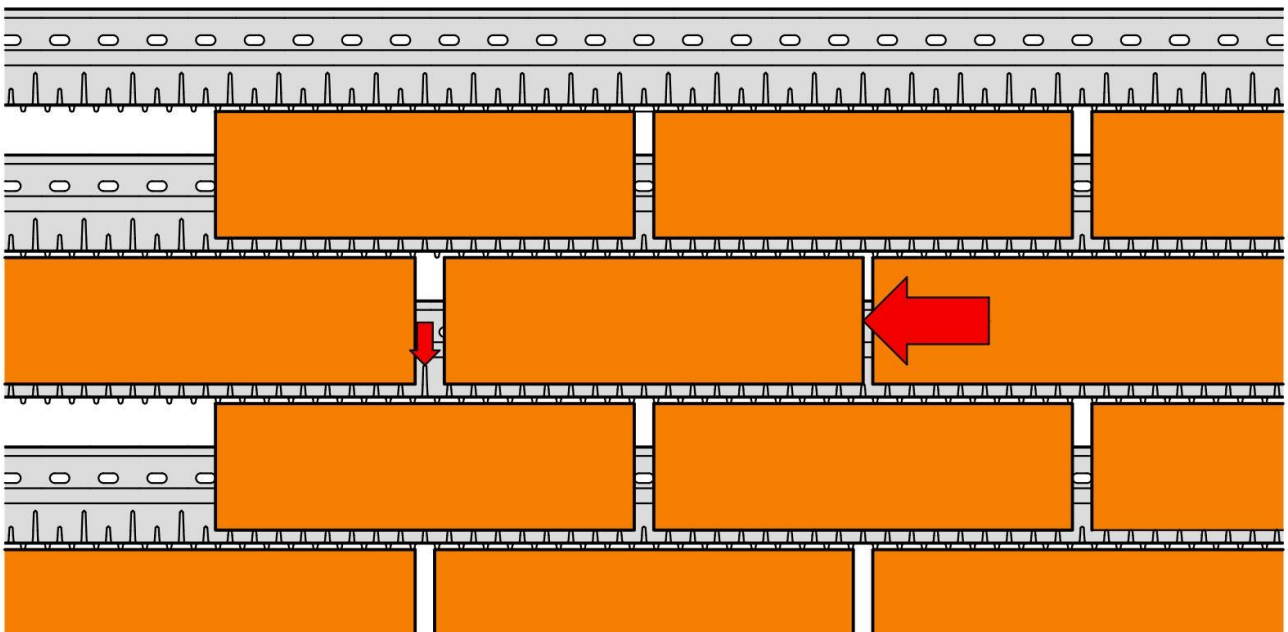

Fig.15

## Barracuda Brick Slip Support System - Installation Guide

### Installation of 'Corner' Brick Slips

Corner brick slips are installed in a similar fashion to the more ordinary 'stretcher' brick slips. However, they should be pushed into the Barracuda brick slip support system at an angle that is not quite perpendicular to the stretcher [long] face of the corner brick slip. Installation can be assisted by the use of a lightweight non-marking elastomeric [rubber] dead blow mallet [James & Taylor can supply the correct/appropriate mallet if required]. See Fig.16. Please also refer to Barracuda Typical Detail: TD-B-107. Always try and insert corner brick slips to 'build up' corners ahead of adjacent 'infill' brick slip work.

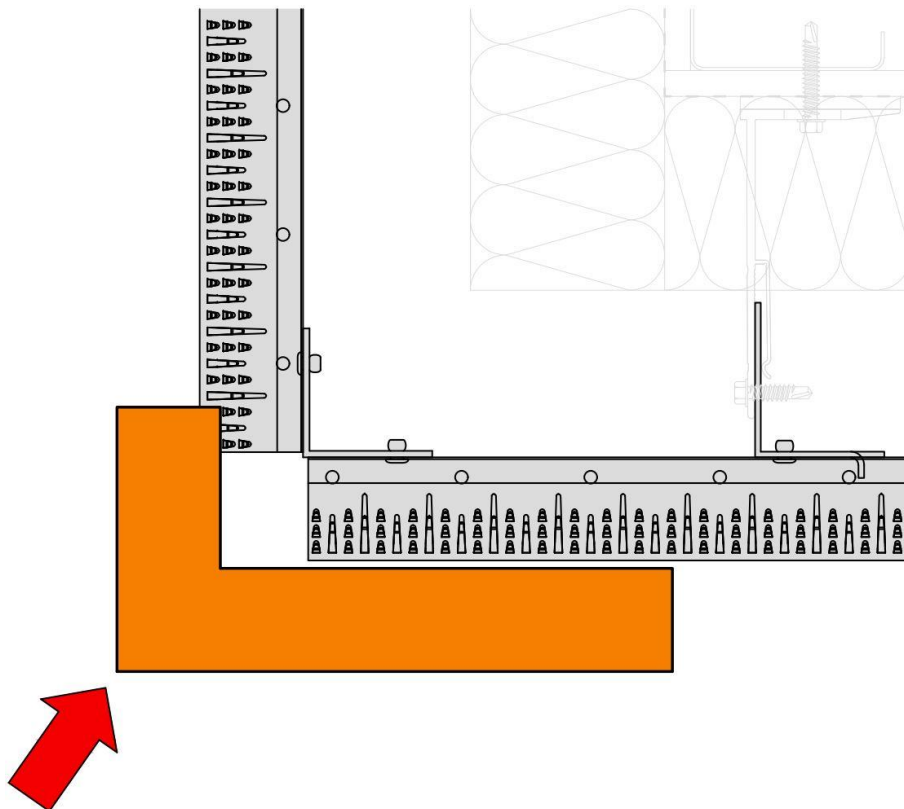

Fig.16

### Installation/Injection of Mortar

If correctly installed, brick slips properly and fully inserted into the Barracuda brick slip support system can be left 'un-mortared' for a limited period of time until it is possible/practicable to mortar that area brick slip façade. Should an area of brick slip façade be left un-mortared, it is important to ensure that mechanical forces [forces other than those derived from the action of wind] do not dislodge or disturb the brick slips. It is recommended that areas of un-mortared brick slips should be cordoned off to prevent access by other trades that are less likely to exercise the same degree of care as the brick slip façade contractor. Brick slips installed into the Barracuda brick slip support system should be mortared as soon as it is possible/practicable to do so. Brick slips installed into the Barracuda brick slip support system must not be left un-mortared for any longer than a 2 week period. All areas accessible to the public or site personnel beneath any area of brick slip façade must be adequately protected from falling debris during the entirety of the construction process.

## Barracuda Brick Slip Support System - Installation Guide

With the brick slips fully inserted into the Barracuda brick slip support system and the brick slips in their finalised position, mortar must be injected into the perpend and bed joints between the brick slips. James & Taylor recommend the use of CPI Euromix mortar M1ANPM000 [or an alternative mortar with equivalent usage and performance characteristics].

There are a number of different mortar injection methods/delivery systems; entirely manual [pump type] guns, electromechanical or pneumatic. The brick slip façade contractor might have their own preference and all can be adequately effective if properly used. James & Taylor recommend the use of an electromechanical auger under hopper device because this will tend not to squeeze the water from the mix and as a result will be less susceptible to clogging. James & Taylor recommend the use of the Quickpoint Plus Electric Mortar Pointing System by Sunrise Tools & Equipment [or alternative with equivalent usage and performance characteristics].

If possible, inject mortar into the joints, working down the panel, from top to bottom. This will tend to keep the panel cleaner. Inject mortar into the perpend joints first. See Fig.17. Fill the perpend joints from the bottom up making sure that the perpend joints are fully filled. The mortar injected into the perpend joints must fill the perpend joint to the full depth (thickness) of the 40mm thick brick slip. Fill the perpend joints so that the mortar is just proud of the surface of the brick slips.

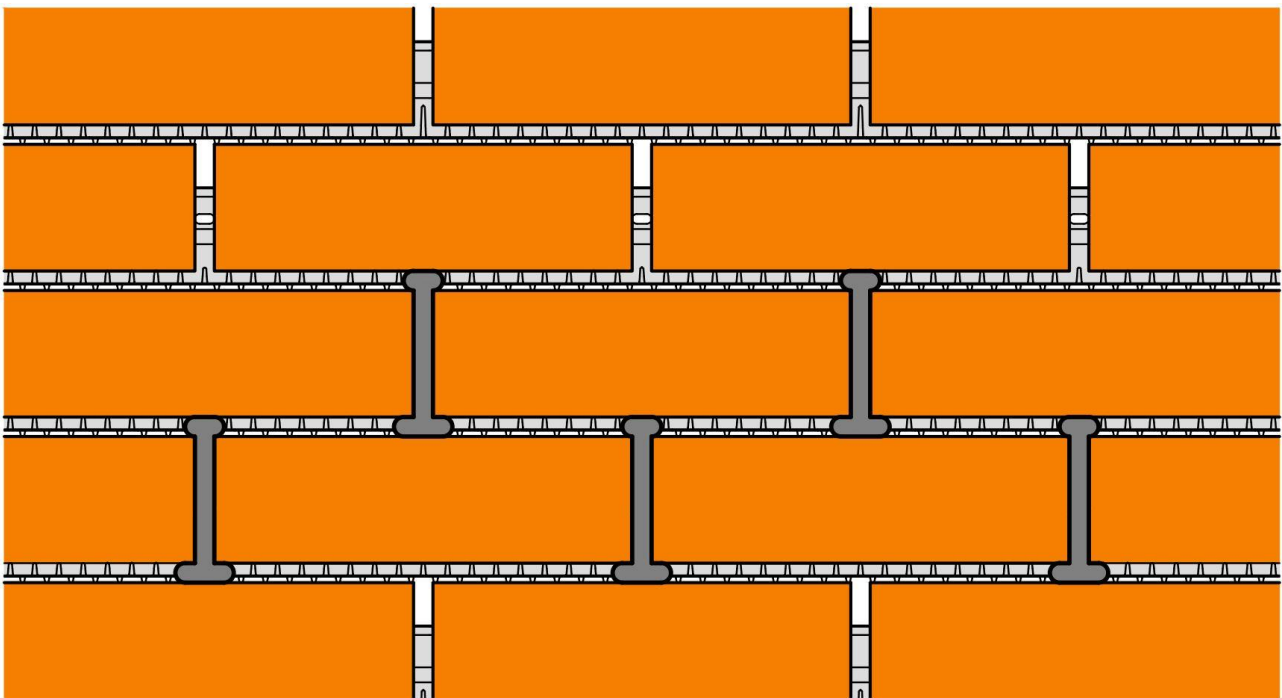

Fig.17

## Barracuda Brick Slip Support System - Installation Guide

Inject a number of perpend joints first but not too many and then fully fill the bed joints. See Fig.18. Usually, injecting 3 or four courses of perpend joints across an area 1.5 to 2M long and then revisiting/falling back to fully fill the bed joints provides a good working rhythm for a single operative.

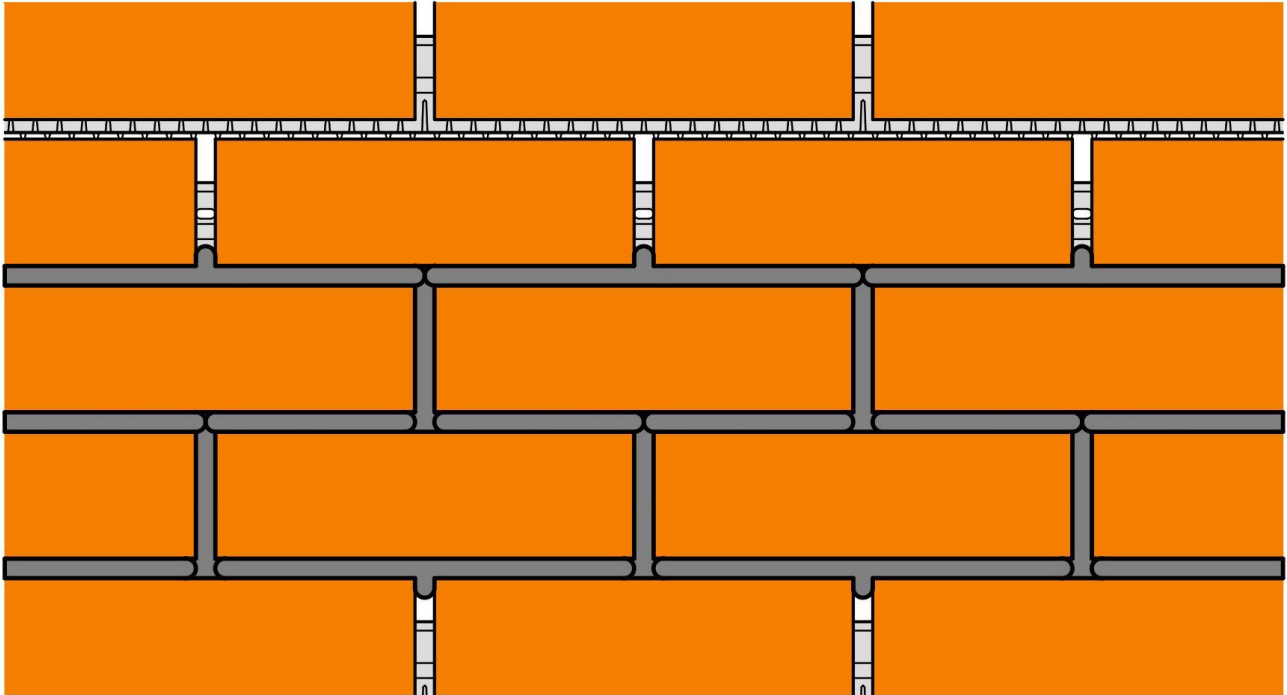

Fig.18

It is important that the bed joints are adequately filled so that the mortar envelopes the teeth on the Barracuda rails. Inject mortar into the bed joints to a minimum depth of 30mm. See Fig.19

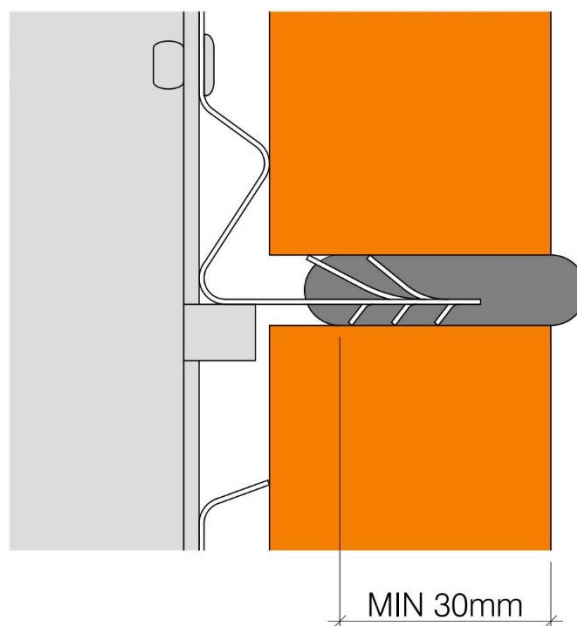

Fig.19

## Barracuda Brick Slip Support System - Installation Guide

Fill all of the joints so that they are just proud of the surface of the brick slips. Fill all of the joints adequately so that when they are 'tooled off', the mortar is suitably compacted by the tooling off process. The mortar joint face profile must be a shallow [22mm or 7/8"] 'Bucket Handle' profile. See Fig.20

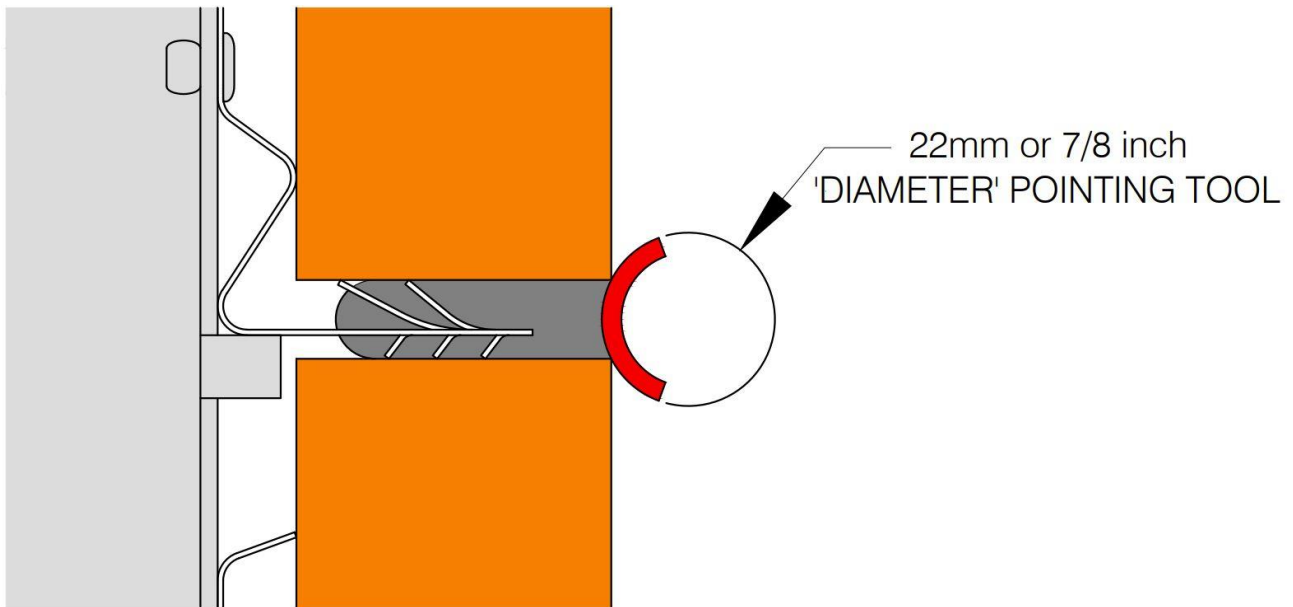

Fig.20

Never work with [inject] mortar into the Barracuda brick slip support system when it is too cold [below the minimum temperature recommended by the mortar manufacturer] or when it is likely to become too cold before the mortar has adequately set. Never mortar when it is raining unless you can be certain that the work area/brick slips are adequately protected/shielded from the rain. Allow 28 days for the mortar to attain its maximum [working] strength. Care must be taken to ensure that the brick slip façade is not subjected to any significant impacts or other disturbance during this 28 day period. After the 28 day period has elapsed, the surface of the brick slip façade may be brushed (with a soft brush) to remove any small loosely adhered mortar deposits and washed down with clean water if required.

